

**CZT4033**  
**SURFACE MOUNT**  
**PNP SILICON TRANSISTOR**

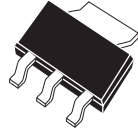

**SOT-223 CASE**

# Central<sup>TM</sup>

**Semiconductor Corp.**

**DESCRIPTION:**

The CENTRAL SEMICONDUCTOR CZT4033 type is a PNP silicon transistor manufactured by the epitaxial planar process, epoxy molded in a surface mount package, designed for high current general purpose amplifier applications.

**MARKING CODE: FULL PART NUMBER**

**MAXIMUM RATINGS:** ( $T_A=25^\circ\text{C}$ )

	<b>SYMBOL</b>		<b>UNITS</b>
Collector-Base Voltage	$V_{CB0}$	80	V
Collector-Emitter Voltage	$V_{CEO}$	80	V
Emitter-Base Voltage	$V_{EBO}$	5.0	V
Continuous Collector Current	$I_C$	1.0	A
Peak Collector Current	$I_{CM}$	1.5	A
Power Dissipation	$P_D$	2.0	W
Operating and Storage			
Junction Temperature	$T_J, T_{stg}$	-65 to +150	$^\circ\text{C}$
Thermal Resistance	$\theta_{JA}$	62.5	$^\circ\text{C/W}$

**ELECTRICAL CHARACTERISTICS:** ( $T_A=25^\circ\text{C}$  unless otherwise noted)

<b>SYMBOL</b>	<b>TEST CONDITIONS</b>	<b>MIN</b>	<b>MAX</b>	<b>UNITS</b>
$I_{CBO}$	$V_{CB}=60\text{V}$		50	nA
$I_{EBO}$	$V_{EB}=5.0\text{V}$		10	nA
$BV_{CBO}$	$I_C=10\mu\text{A}$	80		V
$BV_{CEO}$	$I_C=10\text{mA}$	80		V
$BV_{EBO}$	$I_E=10\mu\text{A}$	5.0		V
$V_{CE(SAT)}$	$I_C=150\text{mA}, I_B=15\text{mA}$		0.15	V
$V_{CE(SAT)}$	$I_C=500\text{mA}, I_B=50\text{mA}$		0.50	V
$V_{BE(SAT)}$	$I_C=150\text{mA}, I_B=15\text{mA}$		0.90	V
$V_{BE(SAT)}$	$I_C=500\text{mA}, I_B=50\text{mA}$		1.10	V
$h_{FE}$	$V_{CE}=5.0\text{V}, I_C=0.1\text{mA}$	75		
$h_{FE}$	$V_{CE}=5.0\text{V}, I_C=100\text{mA}$	100	300	
$h_{FE}$	$V_{CE}=5.0\text{V}, I_C=500\text{mA}$	70		
$h_{FE}$	$V_{CE}=5.0\text{V}, I_C=1.0\text{A}$	25		
$f_T$	$V_{CE}=10\text{V}, I_C=50\text{mA}, f=1.0\text{MHz}$	100		MHz
$C_{ob}$	$V_{CB}=10\text{V}, I_E=0, f=1.0\text{MHz}$		20	pF
$C_{ib}$	$V_{EB}=0.5\text{V}, I_C=0, f=1.0\text{MHz}$		110	pF

**SOT-223 CASE - MECHANICAL OUTLINE**

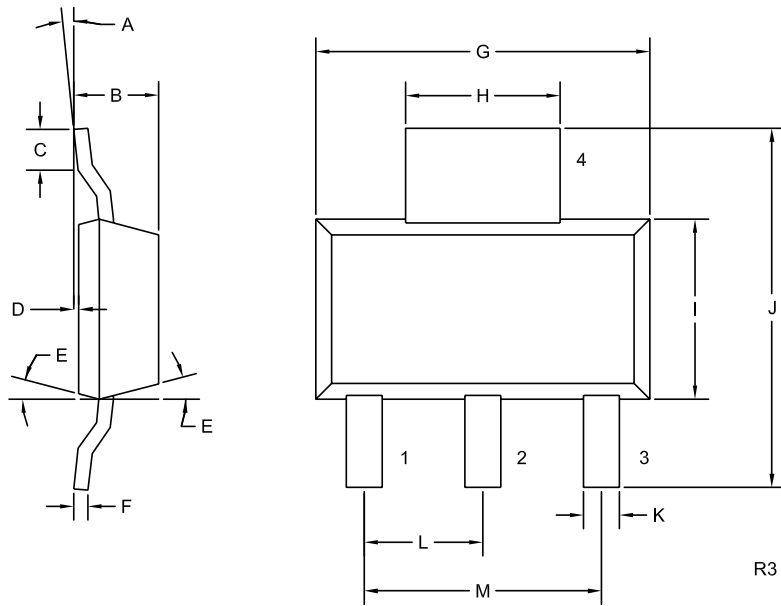

**LEAD CODE:**

- 1) BASE
- 2) COLLECTOR
- 3) EMITTER
- 4) COLLECTOR

**MARKING CODE:**

**FULL PART NUMBER**

DIMENSIONS				
SYMBOL	INCHES		MILLIMETERS	
	MIN	MAX	MIN	MAX
A	0°	10°	0°	10°
B	0.059	0.071	1.50	1.80
C	0.018	---	0.45	---
D	0.000	0.004	0.00	0.10
E	15°		15°	
F	0.009	0.014	0.23	0.35
G	0.248	0.264	6.30	6.70
H	0.114	0.122	2.90	3.10
I	0.130	0.146	3.30	3.70
J	0.264	0.287	6.70	7.30
K	0.024	0.033	0.60	0.85
L	0.091		2.30	
M	0.181		4.60	

SOT-223 (REV: R3)

R4 (17-June 2004)